

---

ICEL 1009

ICEL  
*Standard*

*ICEL 1009:  
Emergency Lighting  
Central Power Supply Systems  
Standard and Registration Scheme*

JUNE 2000

## Foreword - What is ICEL?

The Industry Committee for Emergency Lighting (ICEL) was originally formed in the UK in 1978 by the Emergency Lighting sections of the British Electrical and Allied Manufacturers Association (BEAMA) and the Lighting Industry Federation (LIF). It was formed as an industry committee to respond to a demand for national standards for Emergency Lighting equipment and is now an independent arm of the LIF.

Since its inception, ICEL has been publishing guidance documents and standards for Emergency Lighting Products and Installations to ensure the best practices available are employed. ICEL continues to provide expert advice and guidance to all specifiers and users on the requirements for Emergency Lighting.

Formed with an independent regulatory committee of representatives from government departments, public authorities and larger end users, ICEL exists to help and guide users, specifiers and contractors in all matters that touch upon the Emergency Lighting Industry world-wide. ICEL has become the foremost UK authority on Emergency Lighting and its representatives serve on BSI committees and represent UK interests within European Committees dealing with Emergency Lighting.

The guides and standards published by ICEL since 1978 are well known and respected world-wide and form the basis of many National Standards prior to the harmonisation of European Standards.

Emergency Lighting Central Power Supply Systems (Central Battery Systems) often provide the most cost-effective solution to the provision of emergency lighting in larger and more complex premises.

In the absence of a national standard for such systems, ICEL published ICEL 1001 Pt.1 1985 to provide a standard for the construction of the equipment which could then be installed and maintained in accordance with BS5266 Pt.1 and CP1007 to ensure reliable, high integrity centralised systems were available.

Within Europe the ICEL 1001 Pt.1 standard has now been used as the basis of a Harmonised standard EN 50171 which will soon be published in the UK as BS 5266 Pt 9: EN50171.

Since almost all emergency lighting Central Power Supply Systems are configured for the individual client or installation requirements and cannot realistically be type tested, there is need for a scheme of registration for the manufacture of systems in accordance with the best industry practices. ICEL 1009 meets that need.

ICEL 1009 Emergency Lighting Central Power Supply Systems. The European standard EN 50171 was positively voted in April 2000. ICEL have produced this ICEL 1009 which is a registration scheme that includes the European requirements with additional sections covering some specific UK facilities. It also provides a registration scheme to ensure appropriate systems are supplied.

**ICEL is the leading UK authority on Emergency Lighting and is also probably the most experienced authority on the subject in Europe.**

**Contents**

| Section  | Page |
|--|------|
| Foreword - What is ICEL? .....   | 2    |
| 1 Scope.....   | 5    |
| 2 Normative References.....  | 5    |
| 3 Definitions .....  | 6    |
| 4 Types of central power supply systems.....   | 9    |
| 4.1 Changeover mode (includes a changeover time of less than 0.5s): .....                          | 9    |
| 4.2 Parallel standby mode: .....   | 9    |
| 4.3 Changeover mode with additional control switch device for central switching of the load: ..... | 10   |
| 4.4 Changeover mode with additional control switch device for partial switching of the load: ..... | 10   |
| 4.5 Non-maintained, changeover mode: .....   | 10   |
| 5 Operating Conditions .....   | 11   |
| 5.1 System Requirements.....   | 11   |
| 5.2 Data to be specified by the supplier: .....  | 11   |
| 6 Construction.....  | 12   |
| 6.1 Structure of enclosure .....   | 12   |
| 6.2 Battery Chargers and Rectifiers for CPS Systems.....   | 13   |
| 6.3 Transformers .....   | 14   |
| 6.4 Switching devices .....  | 14   |
| 6.5 Central Inverters .....  | 15   |
| 6.6 Deep discharge protection device .....   | 16   |
| 6.7 Monitoring and supervision devices .....   | 16   |
| 6.8 Fuses and circuit protective devices.....  | 17   |
| 6.9 Output distribution.....   | 17   |
| 6.10 Cable entry and terminations.....   | 17   |
| 6.11 Internal wiring .....   | 18   |
| 6.12 Electric strength .....   | 18   |
| 6.13 Earth bonding .....   | 18   |
| 6.14 Automatic testing device (optional) .....   | 18   |
| 6.15 Batteries .....   | 19   |
| 6.16 Battery installation and provision for maintenance. ....                                      | 20   |
| 6.17 Equipment marking .....   | 20   |
| 6.18 Warning labels.....   | 21   |
| 7 Information for installation and operation.....  | 22   |
| 8 Product Nomenclature.....  | 23   |
| 9 Requirements; Information to be provided by the system specifier.....                            | 24   |
| 9.1 System reference.....  | 24   |
| 9.2 Input supply.....  | 24   |
| 9.3 Output .....   | 24   |
| 9.4 Load details.....  | 24   |
| 9.5 Battery details .....  | 24   |
| 9.6 Constructional details.....  | 24   |
| 9.7 System details .....   | 25   |
| 9.8 Additional specification.....  | 25   |
| 10 Equipment Information.....  | 25   |
| 10.1 System input current .....  | 25   |
| 10.2 Battery.....  | 25   |
| 10.3 Charger.....  | 25   |
| 10.4 Distribution protection device.....   | 25   |
| 10.5 System test description.....  | 25   |
| 10.6 Physical description.....   | 25   |
| 11 Availability of the ICEL Scheme of Registration of Central Power Supply Systems. ....           | 25   |
| Appendix A - technical Files.....  | 27   |

|            |   |    |
|------------|---|----|
| A 1        | Declaration of Conformity.....                                | 27 |
| A 2        | Proof of Conformity.....                                      | 27 |
| A 3        | Evidence of Product Performance.....                          | 27 |
| Appendix B | - Registration and Marking requirements.....                  | 28 |
| B 1        | Applying for Registration.....                                | 28 |
| B 2        | Conditions of the Scheme.....                                 | 28 |
| B 3        | The marking of central power supply systems to ICEL 1009..... | 28 |
| B 4        | Inspection and Testing Labelling.....                         | 29 |
| Appendix C | - Model specification.....                                    | 30 |
| C 1        | Model Specification.....                                      | 30 |
|            | List of ICEL members .....                                    | 31 |

| <b>Figures</b>  | <b>Page</b> |
|---|-------------|
| Figure 1 - Changeover mode schematic diagram .....  | 9           |
| Figure 2 - Parallel standby mode schematic diagram.....   | 9           |
| Figure 3 - Changeover mode with additional control switching device for central switching of the load schematic diagram ..... | 10          |
| Figure 4 - Changeover mode with additional control switch device for partial switching of the load schematic diagram .....    | 10          |
| Figure 5 - Non-Maintained changeover mode schematic diagram .....   | 10          |
| Figure 6 - ICEL 1009 Label Format.....  | 28          |

## 1 Scope

This Standard specifies the general requirements for central power supply systems for an independent energy supply to essential safety equipment. In particular it covers systems permanently connected to a.c. supply voltages not exceeding 1000 V and that use batteries as the alternative power source. This Standard also explains ICEL registration of central power supply systems and the marking of products to demonstrate compliance with the requirements of the registration scheme.

Central power supplies are intended to energise essential safety equipment in the case of failure of the 'normal supply', for example;

- a) emergency escape lighting
- b) electrical circuits of automatic fire extinguishing installations
- c) paging systems and signalling, safety installations
- d) smoke extraction equipment
- e) carbon monoxide warning systems
- f) specific safety installations related to specific buildings e.g. high risk areas.

A schematic representation of typical central power supply equipment is depicted in Clause 4

The scope of this standard specifically excludes power supplies from 100w upwards and for UPS systems up to 100Amps, that are covered by EN50091-1 or fire alarm systems as covered by EN54.

## 2 Normative References

This Standard incorporates by dated or undated reference, provisions from other publications. These normative references are cited at the appropriate places in the text and the publications are listed hereafter. For undated references the latest edition of the publication referred to applies: -

|                            |   |
|----------------------------|---|
| BS 6290 Pt. 2              | Lead Acid stationary cells and batteries - Specification for lead acid high performance Planté positive type                            |
| BS 6290 Pt. 3              | Lead Acid stationary cells and batteries - Specification for lead acid pasted positive plate type                                       |
| BS 6290 Pt. 4              | Lead Acid stationary cells and batteries - Specification for lead acid valve regulated sealed type                                      |
| BSEN 60335-2-29            | Battery chargers  |
| BSEN 61032<br>(IEC 61032 ) | Protection of persons and equipment by enclosures - probes for verification   |
| BSEN 61558-2-5             | Safety of power transformers, power supply units and similar. Particular requirements for shaver transformers and shaver supply units   |
| BSEN 61558-2-6             | Safety of power transformers, power supply units and similar. Particular requirements for safety isolating transformers for general use |
| HD 21                      | Poly-vinyl chloride insulated cables at rated voltages up to and including 450/750V   |
| HD 109                     | Specification for cartridge fuse links for miniature fuses  |
| HD 422                     | Low Voltage Air Break Switches  |
| HD 472                     | Nominal Voltage for Low Voltage Public Electricity Supply Voltage   |
| EN 60051                   | Direct acting indicating analogue electrical measuring instruments  |
| EN 60073                   | Specification for coding of indicating devices and actuators by colours and supplementary means   |
| EN 60146                   | Semiconductor converters  |
| EN 60285                   | Sealed nickel cadmium cylindrical rechargeable single cells   |
| EN 60529                   | Degrees of protection provided by enclosures (IP code)  |
| EN 60598-1                 | Luminaires - General Requirements and Tests   |

|                    |   |
|--------------------|---|
| EN 60598-2-22      | Luminaires for Emergency Lighting   |
| EN 60622           | Sealed nickel-cadmium prismatic rechargeable cells  |
| EN 60623           | Vented nickel-cadmium cells   |
| EN 60695-2-1/2     | Glow-wire flammability test on materials  |
| EN 60896-1         | Stationary lead-acid batteries. General requirements and methods of test, Vented types.   |
| EN 60896-2         | Stationary lead-acid batteries. General requirements and methods of test, Valve regulated types.  |
| EN 60898           | Miniature air break circuit breakers for a.c. circuits  |
| EN 60947-2         | Low-voltage switchgear and control gear. Part 2: Circuit breakers   |
| EN 60947-4-1       | Low-voltage switchgear and control gear. Part 4: Contactors and motor- starters. Section 1. Electromechanical contactors and motor-starters |
| EN 61056           | Portable lead acid cells and batteries (valve regulated types)  |
| prEN 50272-2       | Safety requirements for secondary batteries and. battery installations(Currently under preparation by CLC/TC 2IX)                           |
| IEC 269-4 (BS88-4) | Supplementary requirements for fuse-links for the protection of semiconductor devices   |
| IEC 417            | Graphic symbols for use on equipment  |
| ISO 9000           | Quality management and quality assurance standards  |

The following Standards and Guides may be of assistance when designing a Central Power Supply System installation:

|                          |   |
|--------------------------|---|
| BS5266 Pt.1              | Code of practice for the emergency lighting of premises other than cinemas and other specified places of entertainment. |
| BS5266 Pt.7:<br>EN1838   | Lighting Applications Emergency Lighting  |
| BS5266 Pt.8:<br>EN 50172 | Emergency Escape Lighting Systems   |
| BS5266 Pt.9:<br>EN 50171 | Central Power Supply Systems  |
| CP1007                   | Code of practice for the emergency lighting of cinemas, theatres and certain other specified places of entertainment.   |
| ICEL 1006                | Emergency Lighting Design Guide.  |
| ICEL 1008                | Emergency Lighting Risk Assessment Guide.   |

### 3 Definitions

For the purposes of this standard, the following definitions apply:

**a.c. system (often referred to as a central inverter system):** A central power supply system having an a.c. output in the event of failure of the normal supply.

**automatic transfer switching device (ATSD):** A device arranged to connect the emergency supply automatically to the essential safety equipment circuit(s) on failure of the 'normal supply' or to transfer the load from the 'normal supply' to the battery.

**battery charger:** That part of the equipment that provides the charge to the battery from the 'normal supply'.

**central power supply system (CPS-System):** A central power supply system which supplies the required emergency power to essential safety equipment without any restriction in rated output power.

**changeover mode:** A mode in which the emergency power supply source is kept on standby when in cases of failure of the 'normal supply' the emergency power supply is automatically transferred to the essential safety equipment.

**control switch device (CSD):** A device to automatically supply one or several circuits from the emergency power source on failure of the supply to the control switch device (usually a final circuit). CSD is also referred to as a hold off relay. This device may be manually controlled as required by the application, for example to prevent discharging the battery when the building is unoccupied, providing emergency lighting operation may not be inhibited during material times.

**converter:** A device for changing the voltage of a direct current supply.

**d.c. system:** A central power supply system having a d.c. output in the event of failure of the normal supply.

**deep discharge protection device:** A device to protect the battery against deep discharge.

**earth leakage indication:** A device to indicate a leakage path to earth from either pole of the battery or load circuit only when connected to the battery.

**essential safety equipment:** Devices required by the relevant authority to protect people in the event of a hazard.

**inverter:** A device for the conversion of direct current (d.c.) to alternating current (a.c.).

**load profile:** The characteristic of change of output load current with time over the rated duration period. Loads whose timing is unpredictable (e.g. operation of fire shutters) shall be considered to appear at the most onerous time (e.g. at the end of duration).

**low power supply system (LPS-System):** A central power supply system with a limitation of the rated output power of the system at 500 W for 3 hr duration or 1500 W for 1 hr duration.

**mains failure indication:** A device to indicate a failure of the 'normal supply'.

**material times:** Times during which the emergency lighting is required to be illuminated, e.g. at all times that persons are on the premises, or at the times that the normal lighting is not available according to the regulations, conditions of certificate or licence as appropriate.

**minimum output voltage:** Voltage of the emergency output at the end of rated duration.

**nominal battery voltage:** The suitable approximate value of voltage used to designate or identify a system calculated on the basis of 2 V per cell if lead acid cells are used and 1.2 V per cell if nickel cadmium cells are used.

**nominal system voltage:** The declared output voltage of a centrally supplied emergency power system.

**normal supply:** That source of electrical energy used to provide normal power supply.

**parallel standby mode:** A mode in which the emergency power supply source is continuously connected in parallel to the 'normal supply' and supplies power without interruption when the 'normal supply' fails.

**phase or final circuit failure detector:** A device which monitors the 'normal supply' to separate circuits or phases and which automatically initiates the emergency power supply on failure of the 'normal supply' to any of the monitored circuits.

**rated duration of the system:** The designed period of time during which the load can be supplied whilst the system stays within specified voltage limits.

**rated input current:** The current rating per phase of the power supply equipment for connection to the mains.

**rated output current (of a system):** The current, in amperes, of a system supplied at nominal voltage.

**rated supply voltage (mains input):** The supply voltage or voltages assigned to the equipment by the manufacturer for the specified operating condition of the equipment.

## 4 Types of central power supply systems

In order to comply with the different operating requirements of the essential safety equipment, various types of central power supply systems are necessary.

This clause describes the basic types and their essential characteristics.

In general two different modes of power supply are defined, i.e. the changeover mode and the parallel standby mode. The main difference is the response (changeover) time. In the changeover mode, the response time shall not exceed 0.5 s. whilst in the parallel standby mode, the response is immediate (see section 6.4).

Sections 4.1 to 4.5 show possible changeover mode and parallel standby mode configurations.

### 4.1 Changeover mode (includes a changeover time of less than 0.5s):

In this case the essential safety equipment is supplied directly from the system (see Figure 1). Where the load voltage differs from the 'normal supply' voltage, an isolating transformer is used for supply matching. In the event of power failure, the voltage monitor in the automatic transfer-switching device (ATSD) switches over the supply to the battery. A controlled battery charger provides charging of the battery.

In the case of a 'normal supply' failure, the load, the level of discharge and the capacity of the battery determine the rated duration of the system. Where the load requires an a.c. supply an inverter is included in the circuit. Where a d.c. nominal system voltage differing from the battery voltage is required a converter circuit is included.

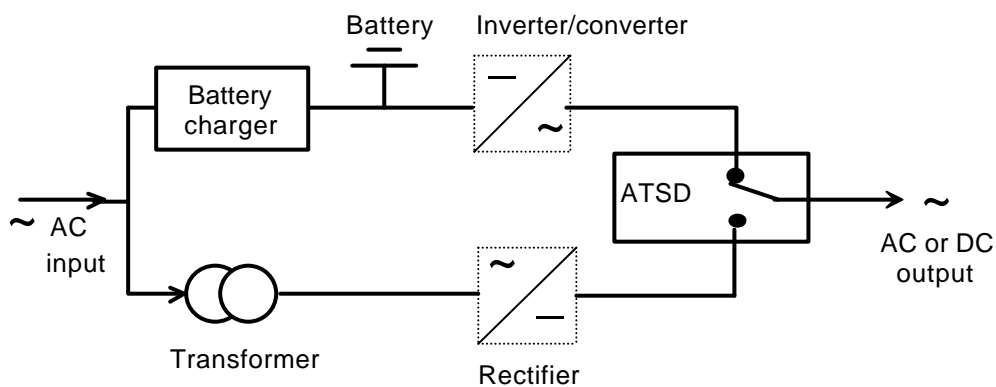

Figure 1 - Typical changeover mode schematic diagram\*

### 4.2 Parallel standby mode:

In this case the charger supplies the essential safety equipment and the controlled charging and/or float charging of the battery (see Figure 2). In the event of a power failure, the battery connected in parallel takes over the power supply to the load without interruption.

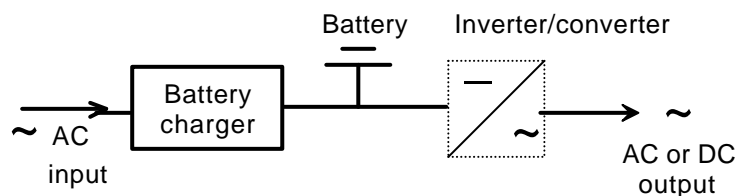

Figure 2 - Typical parallel standby mode schematic diagram\*

\* Optional features shown dotted

**4.3 Changeover mode with additional control switch device for central switching of the load:**

In addition to the devices detailed in 4.1, the equipment includes a control switch device(s) (C.S.D.) which is manually or automatically activated and is dependent upon the 'normal supply' being available, this device ensures that the emergency power supply is not isolated at any material time (see Figure 3).

Note: A number of control switch devices may be used to switch sections of the load.

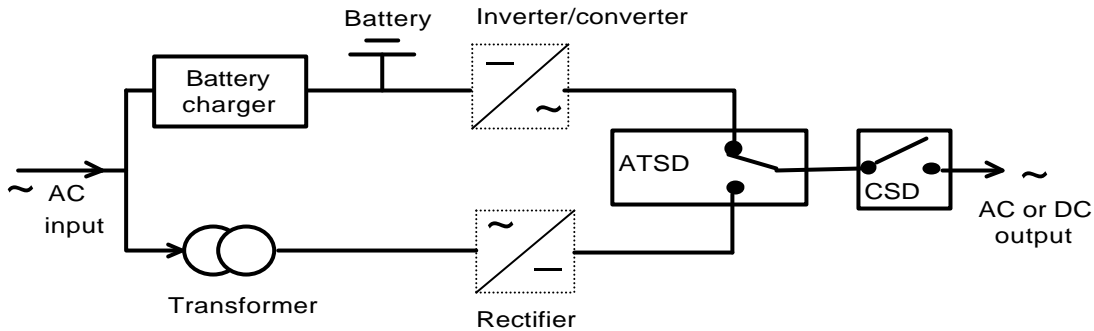

Figure 3 - Typical changeover mode with additional control switching device for central switching of the load schematic diagram\*

**4.4 Changeover mode with additional control switch device for partial switching of the load:**

In addition to the devices detailed in 4.1, the equipment includes a control switch device (CSD) for switching of the load activated by the existing power supply voltage (see 4.3).

In variation to the concept defined in 4.3, part of the load is continuously supplied (see Figure 4)

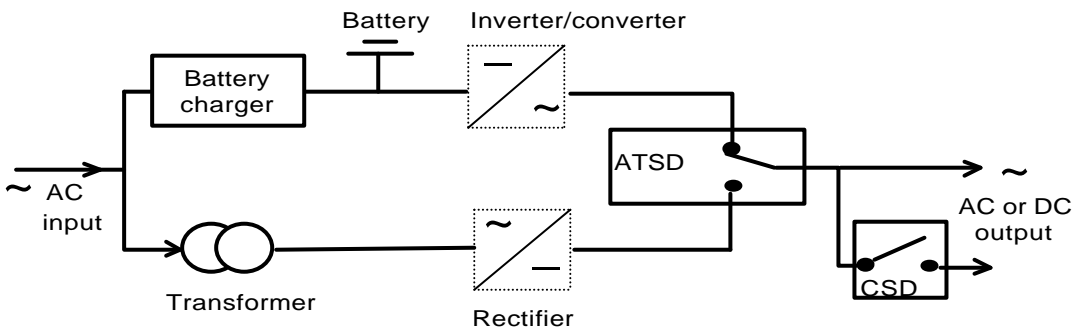
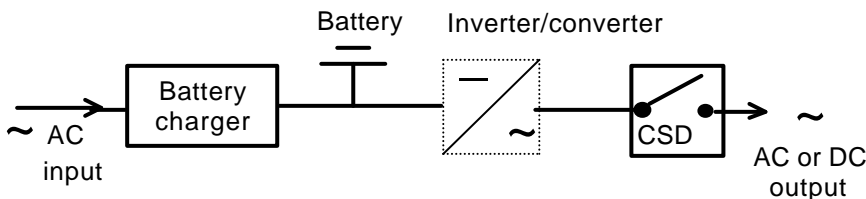

Figure 4 - Typical changeover mode with additional control switch device for partial switching of the load schematic diagram\*

**4.5 Non-maintained, changeover mode:**

In this case the essential safety equipment is supplied only in the event of 'normal supply' failure. The system differs from that defined in 4.2 by using a control switch device(s) (see Figure 5)



Note: the CSD may be positioned between the battery and converter / inverter.

Figure 5 - Typical Non-Maintained changeover mode schematic diagram\*

\* Optional features shown dotted

## 5 Operating Conditions

Normal operating conditions and requirements for equipment:

Devices shall be operated under the following conditions unless user and manufacturer agree the specific variations.

### 5.1 System Requirements

#### 5.1.1 Compliance with EU Directives

The System shall comply with the following EU Directives

- Low Voltage Directive (LVD) (73/23/EEC)
- Electro Magnetic Compatibility Directive (EMCD) (89/336/EEC).
- Construction Products Directive (CPD) (89/106/EEC)

#### 5.1.2 Environmental requirements

- Temperature: The nominal design ambient temperature shall be 20°C, however the system shall be capable of operating in an ambient temperature between 0°C and +40°C. The system emergency operation specification shall indicate derating parameters against temperature.
- Humidity: The equipment shall be capable of operating in a relative humidity (air) up to 85%, non condensing.
- Altitude: The System shall be capable of operating at up to 1000 m above sea level.
- Cooling: The equipment shall be cooled by natural convection or forced convection if parallel redundant cooling equipment is provided.

#### 5.1.3 System Supply

- a) The input voltage shall comply with HD 472, and shall normally be either
  - 230V  $\pm$ 10%, single phase, or
  - 400V  $\pm$ 10%, three phase, 4 wire, or
  - 400V  $\pm$ 10%, three phase, 3 wire.
- b) The frequency of the alternating current input voltage shall be 50 Hz  $\pm$  2 %.

By special arrangement, alternative supply voltages and frequencies may be specified and agreed between the manufacturer and customer.

### 5.2 Requirements for equipment operation:

To enable supply cables and input protective devices to be correctly rated, the following shall be provided:

- a) Maximum Line current, when the system is operating at full load.
- b) Maximum Inrush Line current, together with time / decay characteristics.

## 6 Construction

The equipment shall comply with the following requirements.

### 6.1 Structure of enclosure

6.1.1 Enclosures shall have adequate mechanical strength.

CPS system enclosures should preferably be constructed of metal.

Metal enclosures should be:

- constructed of 1.6mm minimum zinc plated mild steel and
- finished with an etch primer followed by an epoxy based paint.
- Other enclosure materials shall be agreed between the manufacturer and buyer.

Compliance shall be checked by inspection and the following test: -

A straight and unjointed test finger is used with the same dimensions as the standard test finger specified in BSEN 61032:1988 Figure 7 - test probe 11. The finger is pressed against the surface with a force of 30N. During, the test minimum creepage distances and clearances shall be maintained. After the test covers shall not be permanently deformed and the enclosure shall continue to meet the requirements of Section Eleven of EN 60598-1.

6.1.2 Enclosures of the system shall have a degree of protection of at least IP 20.

6.1.3 Enclosures of the system shall be resistant to heat and fire.

Compliance shall be checked by subjecting a sample of the material to the 850°C glow wire test specified in IEC 695-2-1. Fire Hazard Testing, Part 2: Test methods, glow wire Test and Guidance. This test is identical to that specified in EN60598.2.22

Note: Metal enclosures are deemed to comply with this requirement.

6.1.4 Where fitted, indicators, switches or audible devices shall be adequately visible, accessible or audible as appropriate for normal use.

6.1.5 Doors and removable panels shall be so fastened that access to dangerous live parts is not possible without the use of a tool or key.

6.1.6 Devices within the enclosure shall be arranged to facilitate maintenance and functional tests.

6.1.7 The arrangement of interconnections between components and equipment shall be adequately and permanently identified.

6.1.8 Wire-ways shall be smooth and free from sharp edges, burrs, flashes etc, which might cause damage to the insulation of the wiring parts. Metal screws shall not protrude into wire-ways.

6.1.9 Enclosures housing batteries shall meet the requirements of prEN50272-2.

Compliance with the requirements of 6.1.4. to 6.1.9 is checked by inspection.

## 6.2 Battery Chargers and Rectifiers for CPS Systems

Battery chargers and rectifiers shall comply with the following requirements:

- 6.2.1 Battery chargers and rectifiers shall comply with the relevant requirements of BSEN 60335-2-29, EN 60146 and prEN 50272-2
- 6.2.2 Battery chargers shall be designed with full regard to the battery manufacturer's data and recommendations so as to optimise the battery service life.
- 6.2.3 Battery chargers shall be of a controlled rectifier type and shall be capable of automatically charging the associated battery that has been discharged so that it can perform at least 80% of the specified duration with the rated load applied, within 12 h on charge at a room temperature of  $(20 \pm 5)^{\circ}\text{C}$ .
- 6.2.4 Battery chargers shall be capable of automatically recharging the discharged battery so that it can perform 100% of its' specified emergency duration within 24 h on charge.

In the case of parallel standby mode where the load is supplied from the charger, the nominal output current of the charger shall be equivalent to at least 110 % of the sum of the specified load and battery recharge current required to enable the requirements of 6.2.3 and 6.2.4 to be achieved.

Compliance shall be checked by carrying out the test given in 6.2.7.

- 6.2.5 Where maintained loads are permanently connected in the parallel standby mode, the design of the battery charger and its associated system shall be such that the voltage appearing at the output terminals shall not exceed the maximum rated voltage of the loads.  
Battery chargers shall be regulated. The voltage regulation of the system including the load, but without the battery connected, with the battery replaced by a simulated battery, under steady state conditions (excluding current limit conditions), shall be better than  $\pm 2\%$  under all charge conditions and under all normal supply conditions.  
Transients and other ripple type excursions can be accommodated provided that, with the battery disconnected but the load connected to the load terminals, the system peak to peak voltage, including the regulation limits, falls within  $\pm 2.5\%$  of the recommended float voltage of the battery.
- 6.2.6 Battery chargers shall incorporate smoothing circuits. The current flowing through the battery, when it is operating under quiescent charge conditions, shall not reverse into discharge mode<sup>1,2</sup>.
- 6.2.7 Battery chargers shall provide their rated performance over their designed ambient temperature range when operating on normal mains supply voltage. Automatic temperature compensation of battery charge voltage shall be provided if the battery is of the lead acid type or is a requirement of the battery manufacturer.

Compliance shall be checked by inspection and the following test: -

The battery shall be charged for 24 h at a room ambient temperature of  $20(\pm 5)^{\circ}\text{C}$  by application of the minimum rated supply voltage to the battery charger at nominal conditions. Immediately following the charge, the battery shall be discharged using the designed load or equivalent to provide rated output current at the nominal battery voltage. The discharge shall be continued for the rated duration of the system ensuring, at the end of discharge with the load continuing to be operated, that battery voltage provided is not less than 90% of the nominal battery voltage.

The system shall be recharged at the minimum rated input voltage for 12 h at a room ambient temperature of  $20 (\pm 5)^{\circ}\text{C}$ . Immediately following the recharge, the battery shall be discharged at rated output current for

---

<sup>1</sup> For new technology cells, reverse charge may be acceptable. Data from the cell manufacturer shall be submitted to substantiate this claim.

<sup>2</sup> Quiescent charge is regarded as the long term charge following the initial high current charge after a discharge.

80% of rated duration at which time, with the load continuing to be operated, the battery voltage shall be not less than 90% of the nominal battery voltage.

Equipment that does not pass this test shall be re-tested. Equipment that does not pass the repeat test shall be deemed not to comply.

6.2.8 The battery charger shall be so designed that a short circuit on its output will not cause damage.

6.2.9 The battery charger shall be protected against damage to components, other than fuse links or other protective device, caused by reversal of battery polarity.

Compliance with the requirements of 6.2.8 and 6.2.9 shall be checked by disconnecting the battery and applying a short circuit and reverse polarity, as appropriate, to the battery charger output. No damage other than operation of protective devices shall occur.

6.2.10 The battery charger shall comply with the following output characteristics:

i) Float Voltage;

- Adjustable between 2.2 and 2.4 volts per cell for lead acid cells at 20°C.
- Adjustable between 1.3 and 1.5 volts per cell for nickel cadmium cells at 20°C.
- Regulation:  $\pm 2.0\%$ , under all charge conditions and under all normal supply conditions.
- Maximum ripple voltage (RMS): 1.5% of the float voltage.
- Maximum ripple current (RMS): as defined in 6.2.5 and 6.2.6.

ii) Boost Voltage (if required);

- Adjustable between 2.4 and 2.6 volts per cell for vented lead acid cells at 20°C.
- Adjustable between 1.5 and 1.7 volts per cell for vented nickel cadmium cells at 20°C.
- Regulation:  $\pm 2.0\%$ , under all charge conditions and under all normal supply conditions.
- The boost voltage shall be controlled such that battery life is not degraded. For example the application of boost voltage shall be timer controlled.

### 6.3 Transformers

Transformers shall comply with the relevant parts of EN 61558-1: Pt.2.

Note: For equipment requiring transformers outside the scope of EN 61558, specific requirements should be agreed between supplier and user.

### 6.4 Switching devices

The switching time of the changeover transfer switch (ATSD) is part of the start-up requirement times specified in EN1838 and the designer shall ensure that the requirements are met by the system

6.4.1 Automatic transfer switching devices and electronic devices of equivalent nature shall conform to EN 60 947-4 -1 and shall be of the appropriate category for the load. The emergency lighting response times are specified in BS5266 Pt 7:EN1838. The switching time of the ATSD shall be adequate to achieve and not to compromise, the required response time for the emergency lighting system.

For CPS systems: The device shall switch both poles of the safety equipment circuit. For LPS systems of up to 24V d.c. nominal rated output, single pole switching is acceptable.

For emergency lighting loads switching thresholds shall conform to EN 60598-2-22. These limits shall apply to the automatic transfer switch and any final circuit monitors and control switch devices.

- 6.4.2 The incoming supply isolation switch or circuit breaker provided shall be of the rotary, switch-fuse or fuse-switch type complying with HD 422; circuit breakers shall comply with EN 60898 or EN 60947-2.
- 6.4.3 Any manual switch or control provided to change the performance of the battery charger to the boost or commissioning level shall be either of the lockable type or shall be fitted inside the enclosure and shall not be accessible without the use of a tool or key.

Compliance with the requirements of 6.4.2 to 6.4.3 is checked by inspection and measurement.

## 6.5 Central Inverters

Central inverters shall comply with the following requirements:

- 6.5.1 Central inverters, their batteries, chargers, and associated control gear, shall be designed so as to ensure that they are a compatible system, with particular regard to frequency, voltage waveform, load capacity and power factors.
- 6.5.2 The output voltage of central inverters shall match the load requirement but be regulated within  $\pm 6\%$  of the nominal system voltage from 20 % to 100 % of load conditions throughout the rated duration of the system. For instantaneous load changes the output voltage may be allowed to vary within  $\pm 10\%$  for up to 5 s.
- 6.5.3 Inverters shall be capable of permanently handling 1220% of the load requirement for the rated durations. Inverters shall also be able to start the full load of a previously unpowered system, within the response time of EN 1838 in the mains failed mode.
- 6.5.4 Sinusoidal inverters shall have a maximum total harmonic distortion (THD), between 20% and 100% load, of 5% measured into a linear load.

Low power systems using non-sinusoidal outputs are acceptable up to 6A (1hr rated duration) or 2A (3hr rated duration) output current provided they are compatible with the load.

- 6.5.5 Central inverters shall have a frequency matching the load, not exceeding 500Hz, with a maximum frequency tolerance of  $\pm 2\%$  of the rated output frequency, over the full battery voltage and load range.

Note: Inverter systems normally operate at 50 Hz.

- 6.5.6 The inverter shall be protected against damage to components, other than fuse links or other protective device, caused by reversal of battery polarity.
- 6.5.7 The inverter shall be protected by fuse links or other protective device against component damage from short circuits applied directly to the a.c. output terminations.

Compliance with the requirements of 6.5.1 to 6.5.7 is checked by inspection, measurement and the relevant tests.

- 6.5.8 The inverter shall be capable of clearing any associated final circuit or distribution circuit fused without shutting down or rupturing its output fuse. Inverters shall recover to normal output automatically within 5 s of the fuse being cleared. The size and type of fuse or protective device fitted in the distribution system shall be specified by the manufacturer.

Compliance is checked by the following test:

A fuse or protective device of the maximum declared value shall be connected across the output terminals. The inverter shall then be switched on and the fuse or protective device shall operate without damage to the inverter, which shall resume its full output voltage within 5 s.

## 6.6 Deep discharge protection device

A deep discharge protective device shall be provided for the protection of the battery and the automatic switching device and shall comply with the following requirements:

a) the minimum operating voltage of the deep discharge protection shall be as defined by the battery manufacturer;

NOTE: Typical values are 0,9 V/cell for nickel cadmium and 1,6 V/cell for lead acid batteries.

b) the response time shall be less than 5 s. The consumption value of the deep discharge protective device shall not be more than 0, 2A per 100 Ah rated capacity of the battery;

c) the operation of the deep discharge protective devices shall be indicated on the control panel of the safety power supply;

NOTE To prevent over discharge the indication may be the switching off of a device.

d) restoration of the normal supply shall automatically reinstate charging;

e) the deep discharge monitor shall only be reset manually after restoration of the normal supply;

f) no additional manual switchgear shall be used in the battery circuit in order to separate the essential safety equipment from the battery.

Operation, measurement and inspection shall check compliance.

## 6.7 Monitoring and supervision devices

6.7.1 The central power supply system shall include facilities for monitoring the system function. The following shall be measured:

- battery voltage;
- battery/charger/discharge current;
- load current (in parallel standby-mode operation)
- output current of the charger (in parallel standby-mode operation).

6.7.2 The following test and monitoring equipment shall be provided:

- a) devices with automatic reset, e.g push button, to simulate a normal supply failure;
- b) isolating devices to isolate the AC supply for checking the duration of the system;
- c) indication of the actual power supply source (normal supply or battery);
- d) indication of the following faults & system condition;
  - float charge voltage (trickle charge current for Nickel/cadmium battery) out of the permissible range;
  - interruption of the battery charging circuit
  - failure in charge equipment; no charge current, although normal supply is available;
  - supply from the battery, although normal supply is available;
  - warning to be given at least ten minutes before deep discharge protection is initiated (CPs systems only);
  - deep discharge protection initiated

When fitted, the following devices shall also provide indication of their operation:

- operation of the insulation monitoring device (earth leakage indication);
- failure of a powered ventilation system for battery cabinet or battery option.

- e) facilities for a remote display of the following indicators via a potential-free contact shall be provided for:
- systems in operation;
  - supply from the battery;
  - system disturbance combined fault indication as specified in item d).

Note: An audible alarm may also be provided.

6.7.3 Failure of the alarm indicator facility shall not prejudice the operation of the power supply.

Inspection and measurement check compliance with the requirements of 6.7.1 to 6.7.3 by disconnecting the battery charger from the battery.

## 6.8 Fuses and circuit protective devices

Fuses other than semi-conductor protection fuses shall comply with HD 109, semi-conductor protection fuses shall be of the special purpose high-speed type, as specified in IEC 269-4.

Double pole protective devices shall comply with IEC 947-2. Protective devices used in d.c. circuits shall be suitably rated for the required d.c. duty.

### 6.8.1 Protection

The following protective devices and circuits shall be provided for CPS systems:

- Input protection for charging circuit
- Input protection for maintained supply
- Protection for control circuit
- Reverse polarity protection for battery
- Double pole battery protection
- Deep discharge battery protection
- Inverter/converter input protection (where applicable)
- Output distribution circuits as specified by the user.

## 6.9 Cable entry and terminations

6.9.1 All incoming terminals shall accommodate cable rated for the maximum system input current as stated in 10.1, plus 20% spare capacity.

6.9.2 All terminals shall be clearly and appropriately labelled as to their function.

6.9.3 Cable entry positions shall be clearly identified.

Cable entry requirements shall be specified.

## 6.10 Internal wiring

6.10.1 Internal wiring used to carry a.c. supply and safety equipment circuits shall be separated from each other either by running through separate compartments or by double insulation.

6.10.2 Wiring of internal power circuits, shall be in 300/500V grade insulation, according to HD 21.7, or better.

For control circuits wiring of a minimum  $0.5\text{mm}^2$  cross section and 0.6 mm insulation thickness, 300/500V grade insulation shall be used. Low power circuits to circuit boards and wiring interconnecting circuit boards may be of a lower cross sectional area and insulation if adequate account of the current and voltage are made.

Compliance is checked by inspection and measurement.

## 6.11 Electric strength

At normal operating temperature, the equipment shall be able to withstand a test voltage between all live terminals and the protective earth terminal or earthing contact.

Compliance shall be checked by the following test:

Following battery recharge, the maintained circuit shall be operated at rated load for a minimum period of 1 h after which the supply mains shall be disconnected. The equipment, with battery disconnected, shall withstand the electrical strength test at  $2U + 1000\text{ V}$  for 1 minute.

## 6.12 Earth bonding

All exposed conductive parts of emergency lighting central power supply equipment shall be bonded to the protective earthing point of the system. Protective earth connections shall be so designed that they do not have to be disconnected for servicing, other than for the removal of the part that they serve or where removal of hazardous voltages from that part is accomplished at the same time.

Earth bonding shall be subjected to the following test: -

### CPS Systems

A current of at least 25A derived from a source with a no-load voltage not exceeding 12V, shall be passed between the protective earthing point and the exposed conductive parts in turn for a minimum of 60 seconds.

The voltage drop between the protective earthing point and the exposed conductive parts shall be measured and the resistance calculated. The resistance shall not exceed 0.1 ohms.

### LPS Systems

A current of at least 10A derived from a source with a no-load voltage not exceeding 12V, shall be passed between the protective earthing point and the exposed conductive parts in turn for a minimum of 60 seconds.

The voltage drop between the protective earthing point and the exposed conductive parts shall be measured and the resistance calculated. The resistance shall not exceed 0.5 ohms.

## 6.13 Automatic testing device (optional)

Where an automatic testing device with a recording facility is used to monitor the installation status instead of the manual test, the testing device shall have the following characteristics:

- a) Continual monitoring of the charge; where monitoring, is periodic, the intervals shall be  $< 5\text{ min}$ .

- b) Cyclical monitoring of switching and functional capacity of the connected load for the emergency power supply (e.g. luminaires).

Test cycle: at least once a week

Test duration: shall be between 10 sec. and 5 min, the total being less than 10 mins per week.

- a) Recording of faults in the emergency power supply.  
b) Fault notification when there is a fault in the transmission route to the central monitoring point.  
c) A facility for manual initiation of the test on the device.

Compliance shall be checked by inspection and test.

## 6.14 Batteries

6.14.1 Batteries for central power systems (CPS) shall be fully compliant with all appropriate standards from following publications:

- BS 6290 Pt. 2 Lead Acid stationary cells and batteries - Specification for lead acid high performance Planté positive type
- BS 6290 Pt. 3 Lead Acid stationary cells and batteries - Specification for lead acid pasted positive plate type
- BS 6290 Pt. 4 Lead Acid stationary cells and batteries - Specification for lead acid valve regulated sealed type
  - EN60896-1 Stationary lead-acid batteries - General requirements and method of tests Part 1: Vented types.
- EN 60896-1 Stationary lead-acid batteries. General Requirements and methods of test, Vented types
- EN 60896-2 Stationary lead-acid batteries. General requirements and methods of test, Valve regulated types
  - EN 60285 Sealed nickel-cadmium cylindrical rechargeable single cells.
- EN 60622 Sealed nickel-cadmium prismatic rechargeable cells
- EN 60623 Vented nickel-cadmium cells

6.14.2 Batteries for Low power systems (LPS) shall be fully compliant, as appropriate, with the following standards:

- EN 61056 Portable lead acid cells and batteries (valve regulated types)
  - EN 60285 Sealed nickel-cadmium cylindrical rechargeable single cells.

6.14.3 Batteries for central power systems (CPS) shall be of a type having a declared design life expectancy of at least 10 years at 20°C ambient temperature.

Batteries for low power systems (LPS) shall be of a type having a declared design life expectancy of at least 5 years at 20°C ambient temperature.

Note: To achieve full performance at the end of life the battery capacity should be sized in accordance with the battery manufacturers' data.

6.14.4 Lead acid batteries designed for automotive use, shall not be used.

6.14.5 The battery and system design shall be capable of meeting the declared performance initially, during and at the end of the stated design life, under the most onerous conditions of mains input

supply voltage and frequency, ambient temperature, humidity and altitude. To calculate required capacity, initial capacity shall be derated by 20%.

Note 1: Batteries are usually rated to meet the specified performance and declared life expectancy at 20°C. Where a battery rated temperature differing from 20°C is agreed between the supplier and user, this shall be stated and derating factors provided.

Note 2: When equipment is operated continuously in an ambient temperature outside the declared range, the equipment manufacturer or supplier should be consulted.

6.14.6 At the end of the rated duration of the system, the output voltage shall be not less than 90% of the nominal battery voltage at the system load terminals, with the nominal load applied.

Compliance is checked by inspection and calculation.

6.14.7 The nominal battery voltage shall be specified.

## **6.15 Battery installation and provision for maintenance.**

6.15.1 To avoid unauthorised operation, the operation of devices used to provide safety isolation between the essential safety equipment and the connected battery shall be controlled through the requirement to use a key or special tool.

6.15.2 Batteries shall be installed and provision for maintenance made in accordance with prEN 50272-2 and manufacturer's recommendations.

6.15.3 Batteries shall be installed in a well-ventilated area, in accordance with prEN 50272-2 and manufacturer's recommendations. Batteries (excluding sealed types) shall be installed, if necessary, on tiered shelves such that the electrolyte levels are visible for maintenance, within an enclosure or on an external rack. The shelving or rack shall be treated so that it is impervious to the effect of battery electrolyte spillage.

Compliance is checked by inspection

## **6.16 Equipment marking**

6.16.1 Equipment shall be clearly and durably marked with equipment function and supplier details and be readily visible after installation.

Durability test compliance shall be checked by the test specified in EN 60 598-1.

6.16.2 Internal and external parts, such as meters, indicators, switches, fuses and terminals shall have their function and ratings identified by durable marking.

6.16.3 The following information shall appear on the rating label of the complete equipment and markings shall be visible after installation (e.g. it may be positioned inside equipment in a visible position) :

- a) Manufacturer's or supplier's name or trademark
  - b) Product nomenclature.
  - c) Manufacturers reference and serial number (in accordance with section 8)
  - d) Mains supply input
    - rated supply voltage (in volts);
    - rated frequency (in hertz);
- rated input current (in amperes);

- number of phases and arrangement.

e) Battery

- type and number of cells

- battery nominal voltage

f) Supply fuse or circuit-breaker rating

g) Output

d.c. systems:

- nominal system voltage (in volts)

- rated output current (in amperes)

- rated output power (normal supply present) (in watts or volt amperes)

- rated output power (normal supply failed) (in watts or volt amperes)

- minimum output voltage.....(in volts) after duration of.....(in hours)

- rated duration of system (in hours)

a.c. systems:

- nominal system voltage ( in r.m.s. volts);

- maximum load (in volt-amperes);

- rated output power (normal supply present) (in watts or volt amperes);

- rated output power (normal supply failed) (in watts or volt amperes);

- rated frequency (in hertz);

- rated duration of system (in hours)

- power factor range;

- waveform description.(non-sinusoidal shall be identified);

- maximum harmonic distortion into linear load;

Nominal ambient temperature range, if different from 5.1.2.

6.16.4 The earth terminal shall be durably identified by the protective earth (ground) symbol complying with the requirements of drawing 417C - IEC - 5019 in IEC417.

Where this symbol appears on a label, the label shall be permanently attached to the main body of the equipment adjacent to the earth terminal.

Compliance with clauses 6.16.2 to 6.16.4 shall be checked by Inspection and test.

## 6.17 Warning labels

6.17.1 A safety sign acceptable to National requirements shall be fixed externally to every panel or door giving access to live parts.

6.17.2 Where vented cells are used a label shall be fixed in a visible position within the battery enclosure indicating:

- whether a battery of the alkaline or the acid type is fitted
- The treatment required after contact with the electrolyte
- Spillage treatment

- A label warning of explosion risks caused by naked flames shall be fixed in a visible position on the exterior of the battery enclosure.

6.17.3 An external warning label shall state "Isolation of the normal supply may not make this equipment safe for maintenance purposes."

Note: Such warnings are necessary because, for example, non-illumination of an indicator lamp does not always indicate that a circuit is dead, and a live circuit could present a hazard to maintenance personnel.

Compliance is checked by inspection.

6.17.4 Equipment sited in a secure area

When equipment is sited in a secure area, a warning sign showing an electrical equipment hazard shall be displayed, as required by the local authority.

Compliance is checked by inspection.

## **7 Information for installation and operation**

The system shall be provided with installation safety and operating instructions as specified in prEN50272-2 and as appropriate to the equipment.

For example: two systems of different vented battery types should not be installed in the same room.

## 8 Product Nomenclature

In order to standardise on product description the following nomenclature shall be used when specifying products that comply with this standard.

Example of system reference or identification

ICEL/ VR10/ 110V/ 2300W/3000VA/ # - DC/ NM/ 3

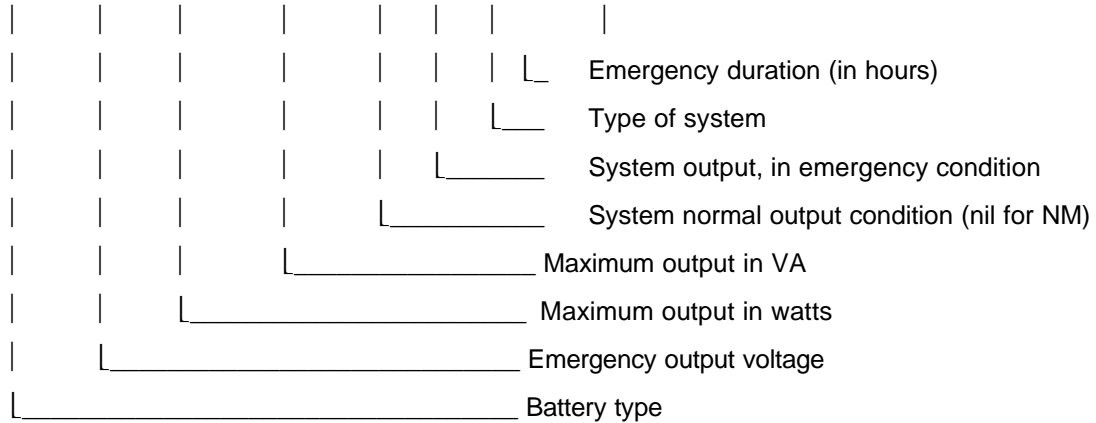

### Battery type

SN Sealed Nickel Cadmium

NC Vented Nickel Cadmium

FP Flat Plate Lead Acid

P Plante Lead Acid

VR10 Valve Regulated 10 year design life

VR5 Valve Regulated 5 year design life (Low power systems only)

Note: New technologies shall be provided with agreed designations upon request.

### Emergency Output voltage

Emergency output voltage (normally 110V, 108V, 50V, 48V or 24V for d.c. systems, 230V or 400V for a.c.systems).

### Maximum output VA

The maximum rating of the load (in VA) to be supported.

### Maximum output Watts

The maximum rating of the load (in Watts) to be supported for the emergency duration for the design life.

### System output in Normal condition

# Nil (not applicable for non-maintained systems)

AC Alternating current

DC Direct current

### System output in Emergency condition

AC Alternating current

DC Direct current

### Type of System

NM Non-maintained

M Maintained

PS Parallel standby

The type of system used depends on the size and function of the premises; see Section 9 of BS 5266 Part 1: 1999

### **Emergency duration**

Normally 1, 2 or 3 hours (3 hours preferred) - for more details on how to specify the duration, consult ICEL 1006.

## **9 Requirements; Information to be provided by the system specifier**

To ensure the correct equipment is supplied, the following information shall be considered:

### **9.1 System reference**

The product nomenclature shall be provided eg. ICEL/ FP/ 50V/ 2000W/2500VA/ AC-DC/ M/ 3

### **9.2 Input supply**

- a) Voltage
- b) Frequency
- c) Phase arrangement

### **9.3 Output**

- a) Voltage
- b) Frequency, if applicable
- c) Power factor, if applicable
- d) Phase arrangement (if applicable)

### **9.4 Load details**

- a) Load profile. (see definition)
- b) Load dynamics e.g. inrush current, crest factor etc.
- c) Maximum permissible load voltage.
- d) Division of the load (maintained and non-maintained operation), as far as required.
- e) Permissible transfer time in case of failure of the mains supply.
- f) Details of distribution and protection requirements.

### **9.5 Battery details**

- a) Battery installation requirements.
- b) Ventilation requirements.
- c) Physical constraints.

### **9.6 Constructional details**

- a) Enclosure material (steel will be assumed).
- b) Cable entry position.
- c) Physical constraints.
- d) IP rating including and vermin proofing requirements.

## 9.7 System details

- a) The required design life.
- b) The ambient temperature range for correct operation of the equipment.

## 9.8 Additional specification

Any other specific requirements to be included

## 10 Equipment Information

The following details shall be supplied by the manufacturer/ supplier

### 10.1 System input current

- Maximum line current when the system is operating at full load and maximum charge rate, at minimum normal supply voltage.
- Maximum inrush current or recommended protective device rating and the period of decay with design load connected.

### 10.2 Battery

- Battery type
- Number of cells
- Battery capacity in Ampere-hours, at C/3 rate.
- Special ventilation requirements.

### 10.3 Charger

- Float voltage setting and the corresponding current limit.
- Boost voltage setting and the corresponding current limit (if applicable).

### 10.4 Distribution protection device

Details of the size and type of fuse or protective devices fitted in the distribution system.

### 10.5 System test description

Details of the method of testing the system shall be provided

### 10.6 Physical description

- Total weight and weight of basic system parts e.g. battery.
- Dimensions of basic system parts.
- Battery accommodation details
- Colour and finish.

## 11 Availability of the ICEL Scheme of Registration of Central Power Supply Systems.

Any organisation assuming design responsibility may obtain approval of the design and supplier of Central Power Supply Systems through assessment as part of the registration of their scheme of quality assurance to at least ISO 9002 in the appropriate sector.

Upon payment of a registration fee to ICEL, all Central Power Supply Systems supplied in accordance with the requirements of the scheme, may display the distinctive ICEL 1009 Registration Mark.

Details of how an organisation may obtain registration to the ICEL 1009 requirements are contained in Appendix B of this standard.

## Appendix A - technical Files

Technical Documentation for CE marking: To CE marking Directive, EMCD, LVD and CPD (Where applicable)

The technical documentation should be provided to facilitate the consultation, administration and performance aspects, in three sections: -

Section A1 is the supplier's declaration of conformity, Section A2 is the proof of conformity relating to the design and production controls and Section A3 is the evidence of product performance. These need not be held in a dedicated Technical File so long as they are traceable and adequate control is provided by the supplier's System of Assessed Capability.

### A 1 Declaration of Conformity

This should contain: -

- A 1.1 Name and address of the supplier or their authorised representative.
- A 1.2 Description and data sufficient to identify the product.
- A 1.3 A reference to Harmonised standards.
- A 1.4 Where appropriate a reference to the specifications (e.g. Installation Instructions with which the conformity is declared).
- A 1.5 Identification of the signatory who has been empowered to enter into commitments on behalf of the manufacturer or their authorised representative.
- A 1.6 Date on which CE marking was affixed.

### A 2 Proof of Conformity

This should include: -

- A 2.1 A general description of the electrical equipment.
- A 2.2 Design and manufacturing drawings and schemes of components, sub assemblies, circuits etc.
- A 2.3 Descriptions and explanations necessary for the understanding of the drawings and schemes referred to above and for the operation of the electrical equipment.
- A 2.4 Results of design calculations, examinations carried out etc.
- A 2.5 Test Reports as defined in A 3.
- A 2.6 Statements on quality control procedures.

### A 3 Evidence of Product Performance

Verification of product performance should be given, i.e. the results recorded, the test equipment and test procedures used. Appropriate performance requirements will vary but evidence of compliance to all relevant clauses of this standard shall be verified.

## Appendix B - Registration and Marking requirements

### B 1 Applying for Registration

Organisations wishing to obtain registration of their central power supply systems in order to be granted an ICEL 1009 licence, should submit a copy of their ISO 9000 series licence and schedule to the Technical Manager of ICEL for acceptance.

### B 2 Conditions of the Scheme

The following conditions shall apply to the Scheme of Registration of central power supply systems:-

- The supply of central power supply systems to ICEL 1009 shall be specifically included in the scope of the ISO 9000 series licence held by the applicant. The Technical Manager of ICEL will inform the auditor of the inspecting authority of all ICEL 1009 licensees.
- Routine testing for system compatibility shall be carried out as described in this document for all applicable central power supply systems.
- Technical files shall be written, if requested, in accordance with this document for central power supply systems.
- The ICEL 1009 marking shall be applied only to those central power supply systems supplied in accordance with the described procedures.

### B 3 The marking of central power supply systems to ICEL 1009

In addition to the markings required to be applied to central power supply systems by this standard, systems manufactured in accordance with this standard may bear the following label: -

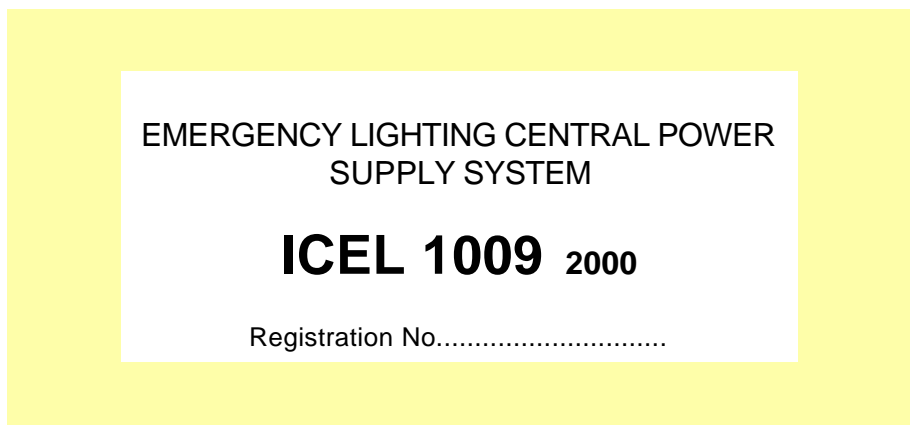

Figure 6 - ICEL 1009 Label Format

The registered organisation is entitled to affix the above label when they have the following: -

- B 3.1 Independently registered their quality assurance scheme to ISO 9000 series with the appropriate schedule to supply central power supply systems in accordance with this standard.
- B 3.2 Registered with ICEL and entered their number on this label.

#### **B 4 Inspection and Testing Labelling**

All central power supply systems shall bear a signed "Inspected and Tested" label or other similar suitable marking and shall be marked in such a way that the date of manufacture can be traced. Such information shall be distinctly and durably marked on the systems in a position that can be seen during maintenance, if necessary after the removal of covers etc.

## Appendix C - Model specification

### C 1 Model Specification

The following model specification is provided to assist specifiers and users in the process of defining system requirements and may be extended as necessary to encompass specific requirements:-

"The central power supply system shall be supplied in conformance with ICEL 1009 and registered under the ICEL 1009 scheme.

The system shall operate in a (*non-maintained/maintained/parallel standby*)<sup>#</sup> mode and shall provide a nominal output voltage of (XX)<sup>Φ</sup> Volts (DC)(AC/DC)(AC)<sup>#</sup> (at XX Hz)<sup>Φ</sup> for an emergency period of (X)<sup>Φ</sup> hours. The system shall be capable of supporting a normal supply load of (XX)<sup>Φ</sup> watts, (XX) VA<sup>Φ</sup> and an emergency load of (XX)<sup>Φ</sup> watts, (XX) VA<sup>Φ</sup>. The system supplier shall verify compatibility of the system with the load profile.

System batteries shall be of the (*sealed lead acid type, fully compliant to BS 6290 Pt.4 / high performance planté lead acid type, fully compliant to BS 6290 Pt.2 / vented nickel-cadmium type, fully compliant to EN 60623*)<sup>#</sup> and shall be provided with all necessary intercell links and connections. Batteries shall be designed to provide the full rated duration, under the rated load conditions for a minimum of (10/15/20/25)<sup>#</sup> years. The battery charger shall be capable of recharging the battery to provide 80% of the rated duration within 12 hours and 100% of the rated duration within 24 hours of a full rated discharge. Batteries shall be installed (*on open stands / in enclosures/in a specific battery room*)<sup>#</sup>. The electrolyte level for vented cells shall be visible for maintenance purposes.

The battery charger shall be regulated in accordance with the requirements of ICEL 1009 to provide the design battery life. Deep discharge protection shall be provided and the discharge current after operation of the device shall be within the limits defined in ICEL 1009.

The system shall be supplied with adequately sized output terminals for the intended load(s) connected through (X)<sup>Φ</sup> (*fuse / MCB*)<sup>#</sup> protected output way(s) of (XX)<sup>Φ</sup> Amps.

The system enclosure(s) shall consist of epoxy coated cabinet(s) fabricated from 1.6mm minimum zinc plated steel. Cable entries shall be provided on detachable plates mounted on the (*side/top/bottom/rear*)<sup>#</sup> surfaces. The cabinet shall be sealed to (IPXX)<sup>Φ</sup> minimum, (*vermin protection shall be provided*)<sup>#</sup>. Ventilation shall be by natural convection unless specifically agreed otherwise, any forced ventilation shall be by a dual redundant system with visual and audible indication of failure, as defined in ICEL 1009.

The central power supply system shall be provided with indicators, meters and alarms in accordance with ICEL 1009. Systems shall be overload rated and protected as defined in ICEL 1009 and all circuits shall be protected against reverse polarity connection of the battery. A fault on one output circuit shall not inhibit output from any other circuits."

---

<sup>#</sup> Delete as necessary

<sup>Φ</sup> Insert details required

## List of ICEL members

A current list of ICEL members together with details of the products each manufactures is available from:  
Industry Committee for Emergency Lighting Limited  
Swan House  
207 Balham High Road  
London  
SW17 7BQ

Tel: +44 (0)20 675 5432

Fax: +44 (0)20 673 5880

E-mail: [info@icel.co.uk](mailto:info@icel.co.uk)

Or visit ICEL Website at [WWW.ICEL.CO.UK](http://WWW.ICEL.CO.UK) for a list of ICEL members and their product ranges.